

Innovative X-ray Solutions

Food inspection: Fish

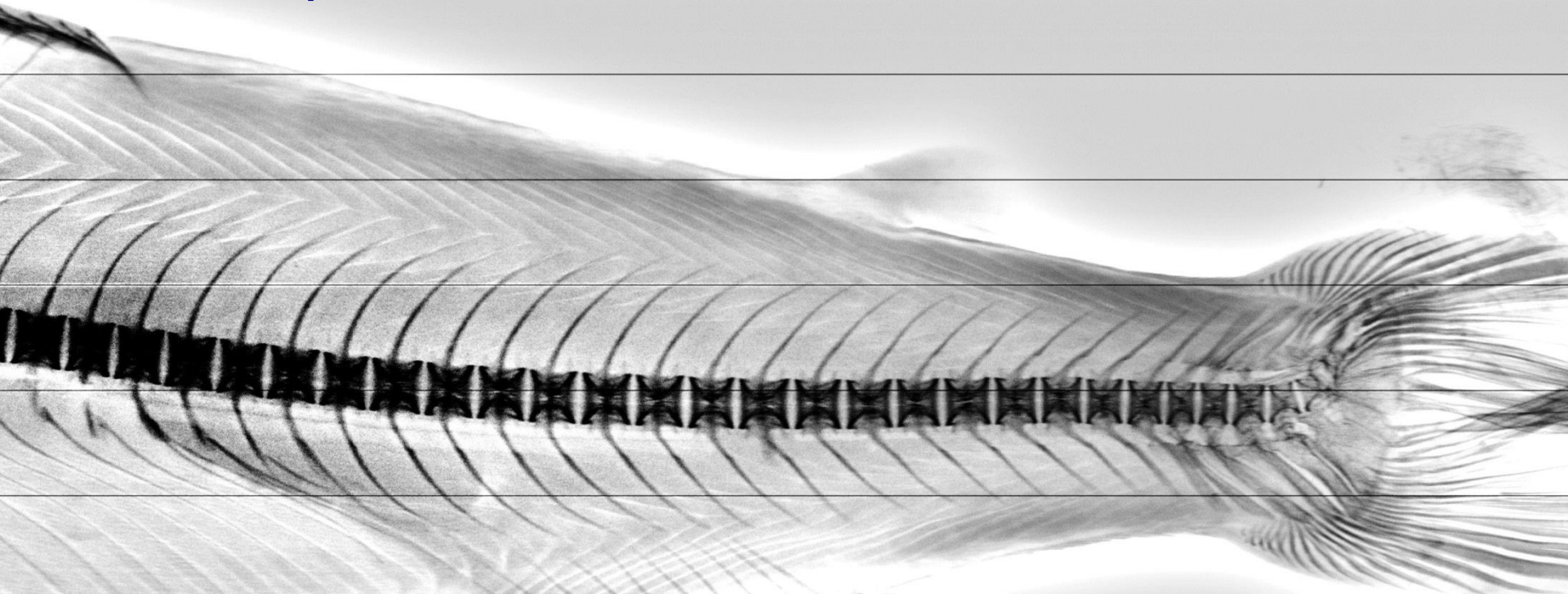

FHF konference
Oslo 27 Nov. 2013



Innovative X-ray Solutions

INNOSPEXION



X-RAYS: Our business

InnospeXion uses the knowledge on X-ray interaction with matter to develop innovative techniques for inspection and characterisation, by imaging or by measurement of the spectrum of transmitted or scattered radiation. Since 2000, we have applied these principles for non-destructive testing services, prototype characterisation, manufacturing prototyping and for the continuous development of state-of-the-art industrial solutions. Since 2003, we have supplied intelligent and unique on-line, at-line or off-line x-ray based solutions to improve the productions cost-effectiveness. **The main success product is the low energy X-ray inspection systems that was awarded the Innovation Award 2007**

Low energy X-ray inspection: 2007

The new MCIS from InnospeXion



**MCIS is based on
low energy X-rays:
Improved contrast
Less radiation
Low weight
Simple design**



Innovation Award

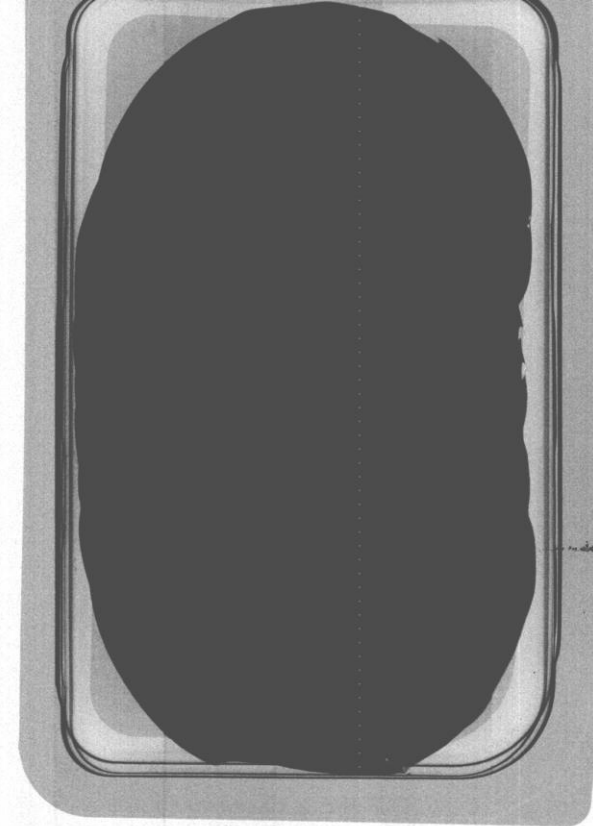
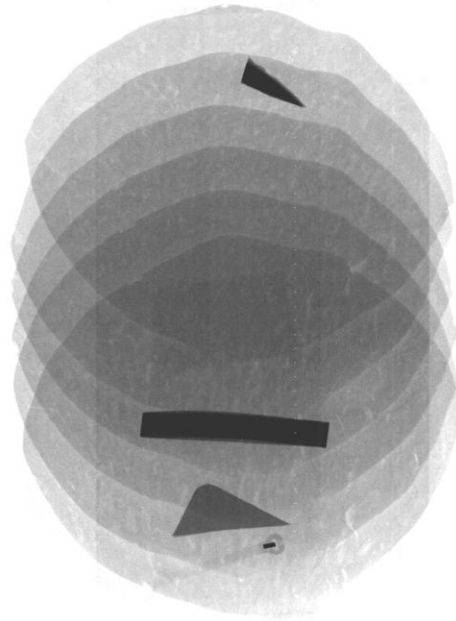
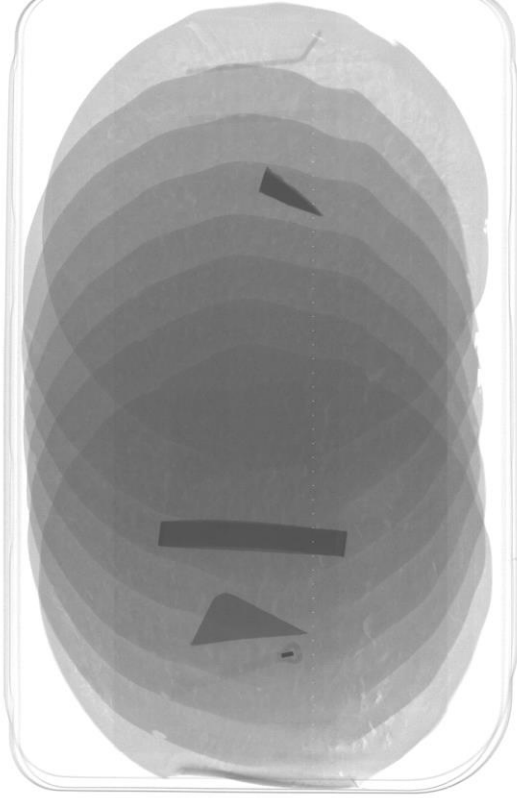

**WORLD CLASS X-RAY
IMAGE QUALITY**



Low energy X-ray inspection: 2009

The HYMCIS from InnospeXion



Second generation:
Hygienic design
Full PLC control

Innovation Award



Low energy X-ray inspection: 2010-2011

The HYMCIS from InnospeXion



**Available in
tailored
versions from
150 to 1600 mm
conveyor width:**

- Hygienic design
- Full PLC control
- 0.1 mm detection
- Ultra high sensitivity

Low energy X-ray inspection: 2011-2012

The HYMCIS from InnospeXion



Third generation:

PLC master - Versatile I/O design

Various Conveyor widths

Tailored design options

Why is the technology interesting for fish bone detection?

Small fish bones gives small contrast. At low energy, the contrast is much higher, and therefore detection is more reliable

Small fish bones requires a high resolution for their detection. 0.1 mm resolution enables detection of bones down to 0.15 mm Ø.

Tailoring to meet the requirements in the fish industry is possible.

LOW-ENERGY X-RAYS

Application Examples

Food inspection: Fish

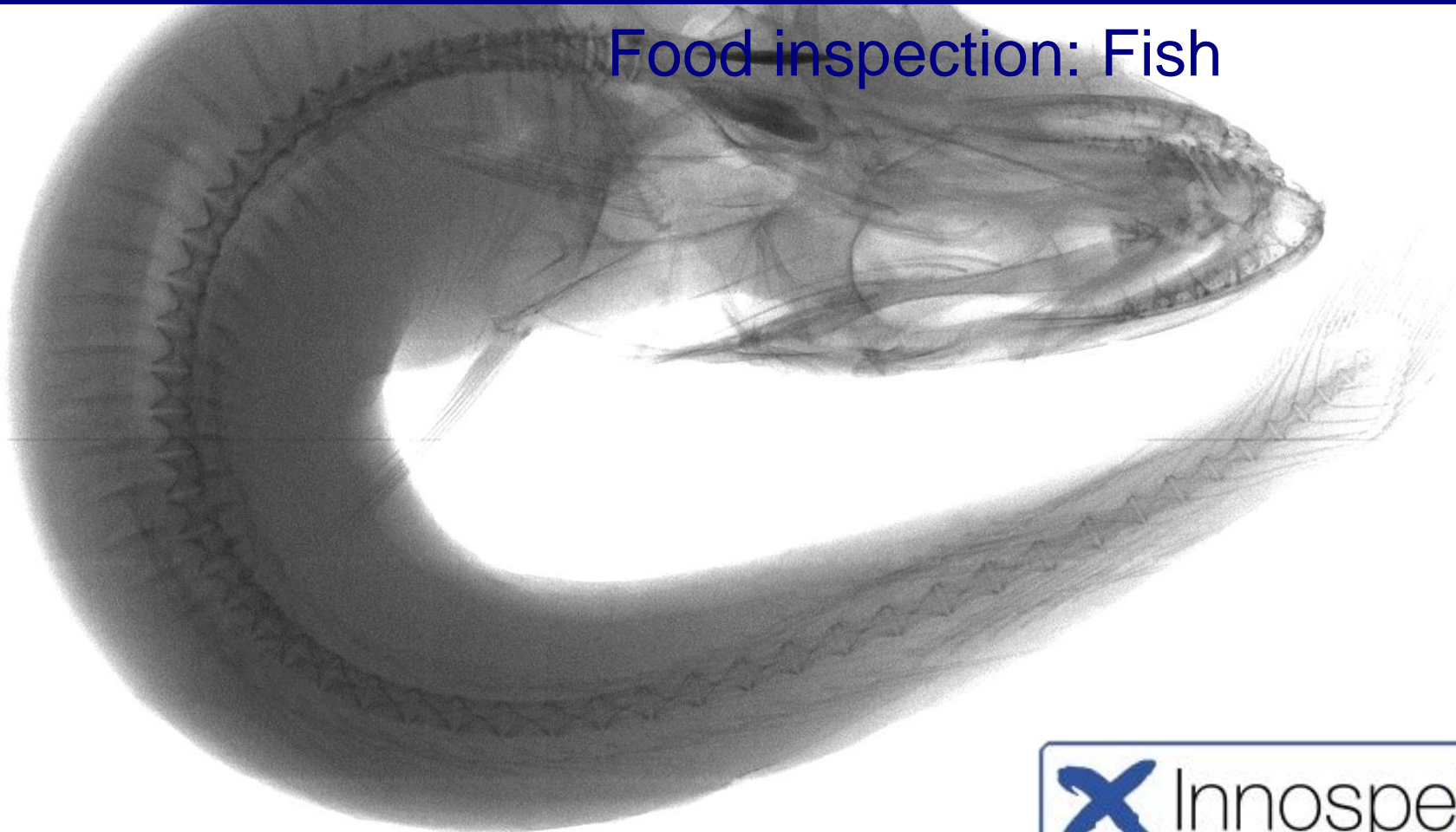

Low energy X-ray inspection

The HYMCIS from InnospeXion

What's that to do with fish?



The ordinary X-ray systems are not - in general - suitable for fish bone detection. There are two main reasons:

1. The systems operate with a pixel size of 0.4×0.4 or 0.8×0.8 mm. This resolution is too coarse for fish bones. We use a special technology involving 0.1×0.1 mm resolution.
2. The systems use a detector that converts the X-ray information "image" using a crystal called Gadax, Gadolinium Oxysulfide. This material is however only effective at X-ray energies above 25 kV. But the contrast between meat and bones in fish is unfortunately optimal at a LOWER energy. Therefore the traditional X-ray systems have difficulty in detecting fish bones, EXCEPT when these are very large, typically mm-sized in diameter.

Our technology is very different as we use a detector that is effective from about 5 kV, meaning that we actually get a very clear image even of tiny bones.

FACTS

- The lower the X-ray energy (in KeV), the better the contrast;
- The smaller the pixel dimension, the better the spatial resolution
- Röntgen unveiled the potential for low E X-rays a century ago

CONSTRAINTS

- Low energy X-rays are easily absorbed – also by air!
- When a pixel is small, it receives very little "light", or radiation. Hence, the SNR in a low E X-ray image may be very poor
- For industrial automation, line speed may be high. Hence, even less radiation is received per pixel per time unit.

THE SOLUTION

- Very stable X-ray source
- Very high quantum efficiency detection technology
- Design that limits the physical constraints

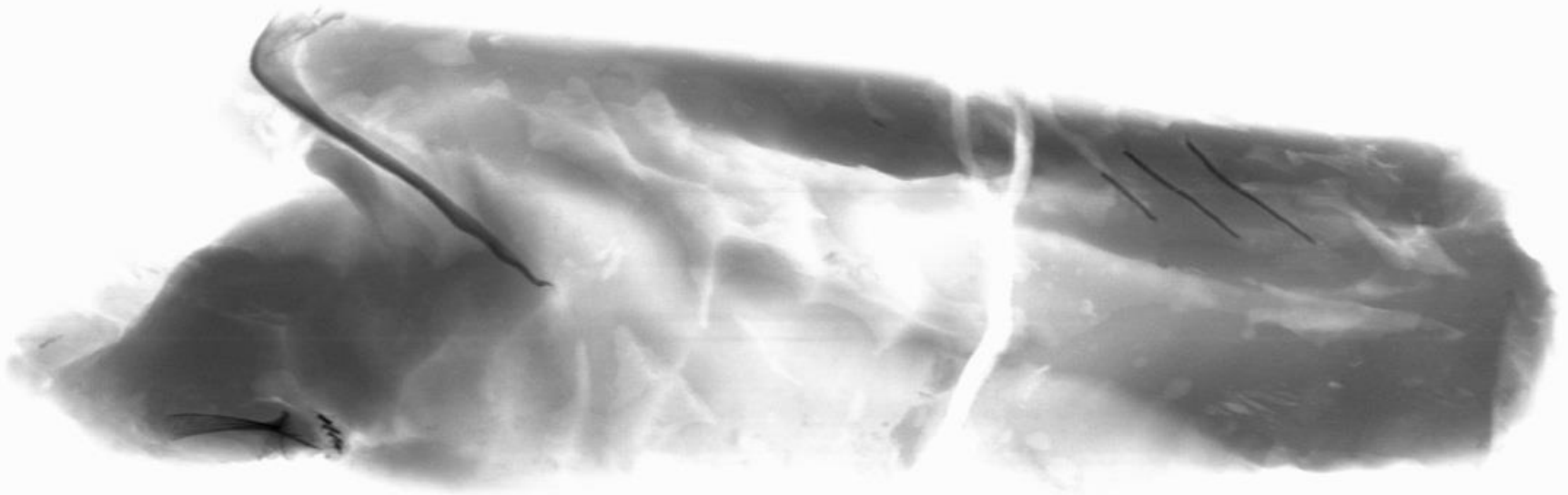

LOW-ENERGY X-RAYS

Application Examples

Food inspection: Fish bones
Automatic detection & identification in fillets

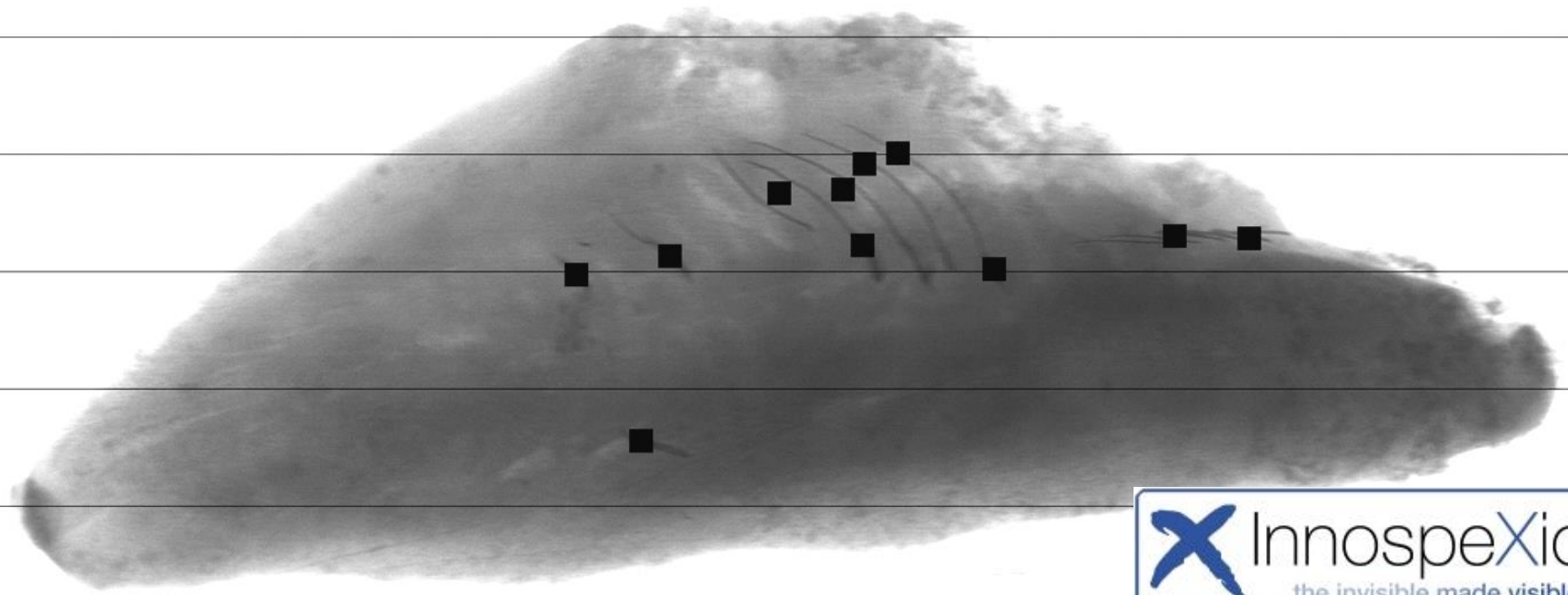



mm	mm	%	mm	mm	%	mm	mm	%	mm	mm	%	mm	mm	%
Bone diameter	Bone length	POD	Bone diameter	Bone length	POD	Bone diameter	Bone length	POD	Bone diameter	Bone length	POD	Bone diameter	Bone length	POD
0,25	5	60	0,35	5	75	0,45	5	81	0,55	5	90	0,65	5	92
0,25	7	61	0,35	7	77	0,45	7	83	0,55	7	92	0,65	7	94
0,25	9	62	0,35	9	78	0,45	9	84	0,55	9	93	0,65	9	95
0,25	11	63	0,35	11	80	0,45	11	86	0,55	11	95	0,65	11	97
0,25	13	64	0,35	13	81	0,45	13	87	0,55	13	96	0,65	13	98
0,25	15	65	0,35	15	83	0,45	15	89	0,55	15	98	0,65	15	98
0,25	17	66	0,35	17	84	0,45	17	90	0,55	17	98	0,65	17	98
0,25	19	67	0,35	19	86	0,45	19	92	0,55	19	98	0,65	19	98
0,25	21	68	0,35	21	87	0,45	21	93	0,55	21	98	0,65	21	98
0,25	23	69	0,35	23	89	0,45	23	95	0,55	23	98	0,65	23	98
0,25	25	70	0,35	25	90	0,45	25	96	0,55	25	98	0,65	25	98
0,25	27	71	0,35	27	92	0,45	27	98	0,55	27	98	0,65	27	98
0,25	29	72	0,35	29	93	0,45	29	98	0,55	29	98	0,65	29	98
0,25	31	73	0,35	31	95	0,45	31	98	0,55	31	98	0,65	31	98
0,25	33	74	0,35	33	96	0,45	33	98	0,55	33	98	0,65	33	98
0,25	35	75	0,35	35	98	0,45	35	98	0,55	35	98	0,65	35	98

Living fish X-ray image

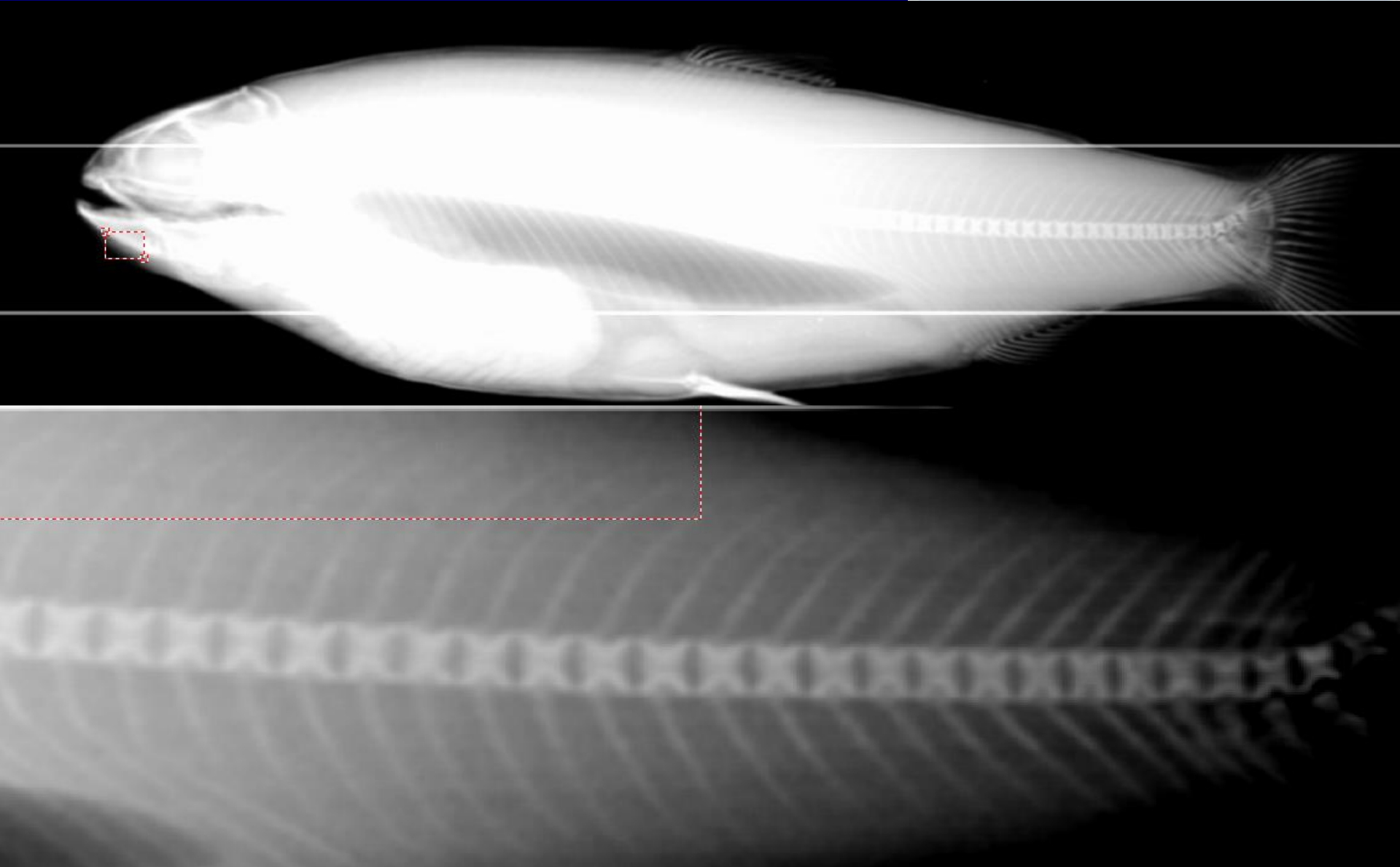

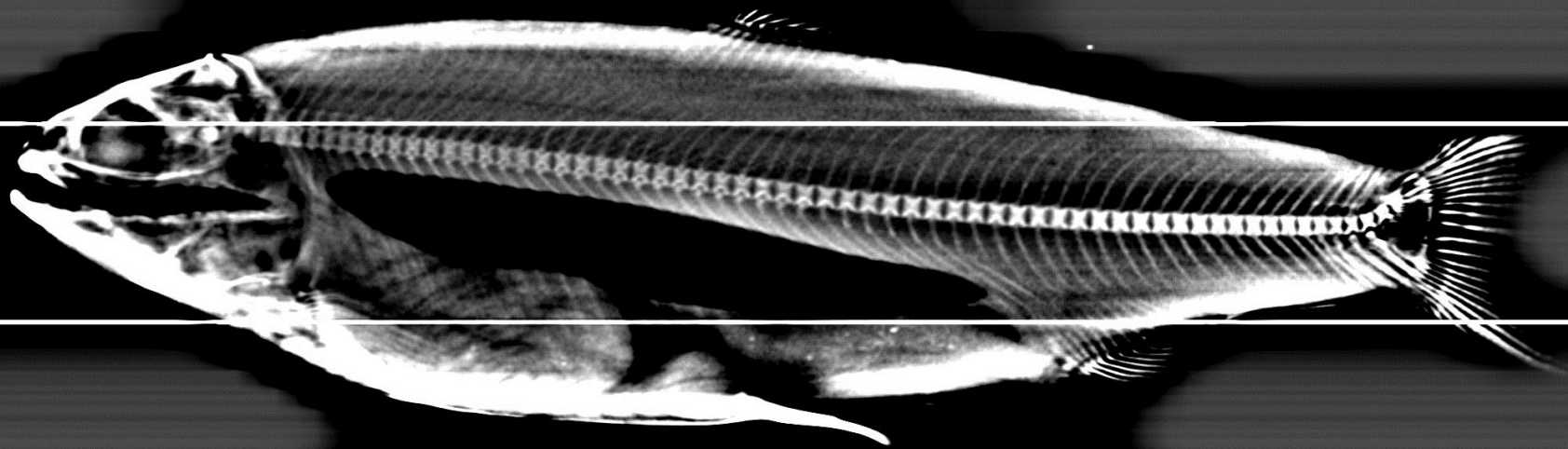
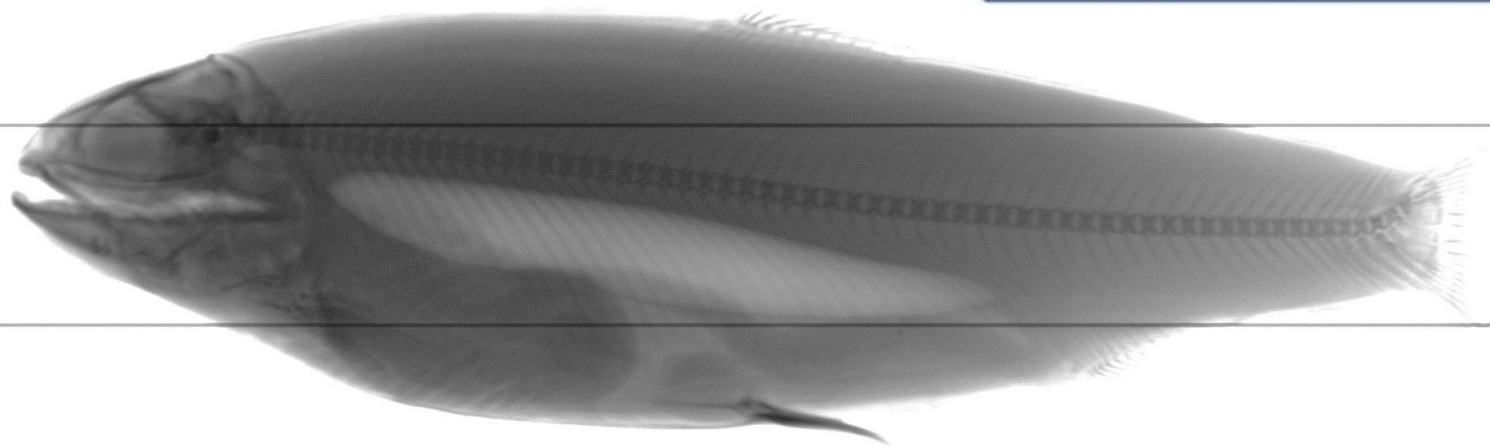

X-ray imaging at high speed: Solutions offered by Low-Energy X-rays



Low-Energy X-ray discloses packaging imperfections

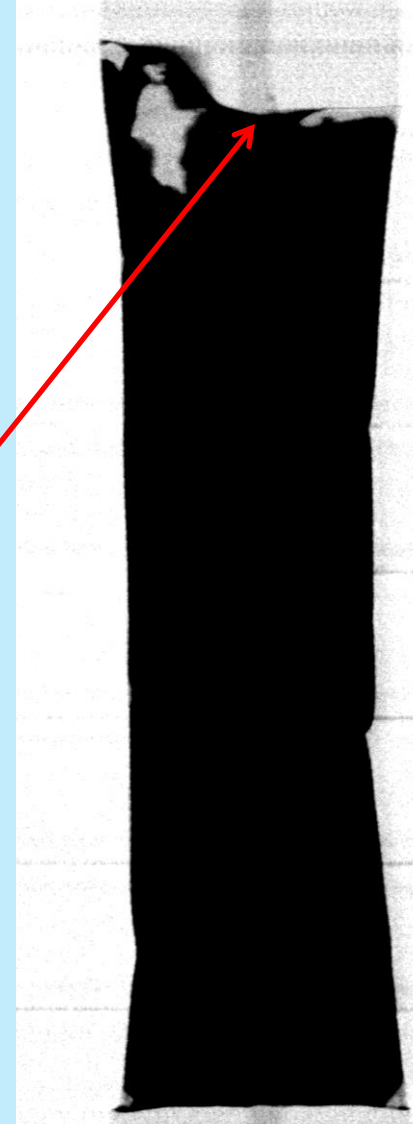
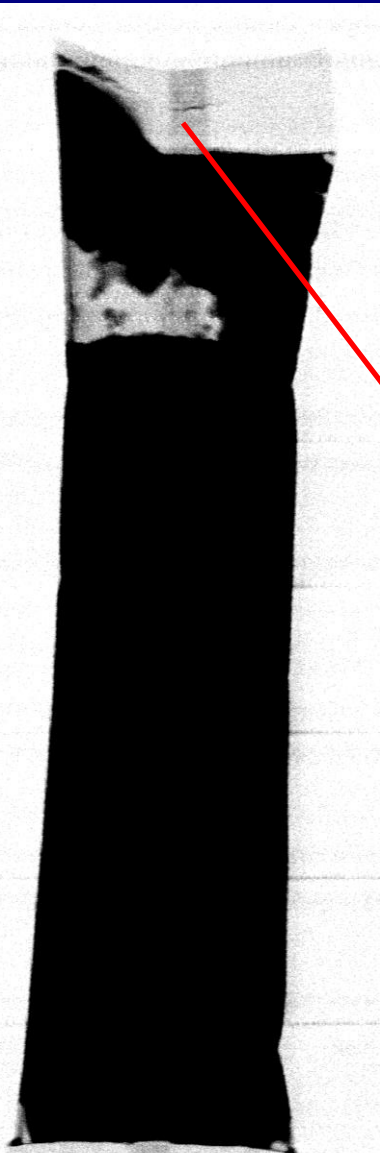

 InnospeXion
the invisible made visible

 InnospeXion
the invisible made visible

Sample 3 with product in seal
Sample 4 with product in seal

LOW-ENERGY X-RAYS



APPLICATION EXAMPLES – Blister packaging



Blister packaged products with defects:
missing objects and damaged objects
(cracks).

Note the huge dynamic range showing
packaging, sample (product) integrity as well
as defects.

Imaged at production speed = 22 m/min

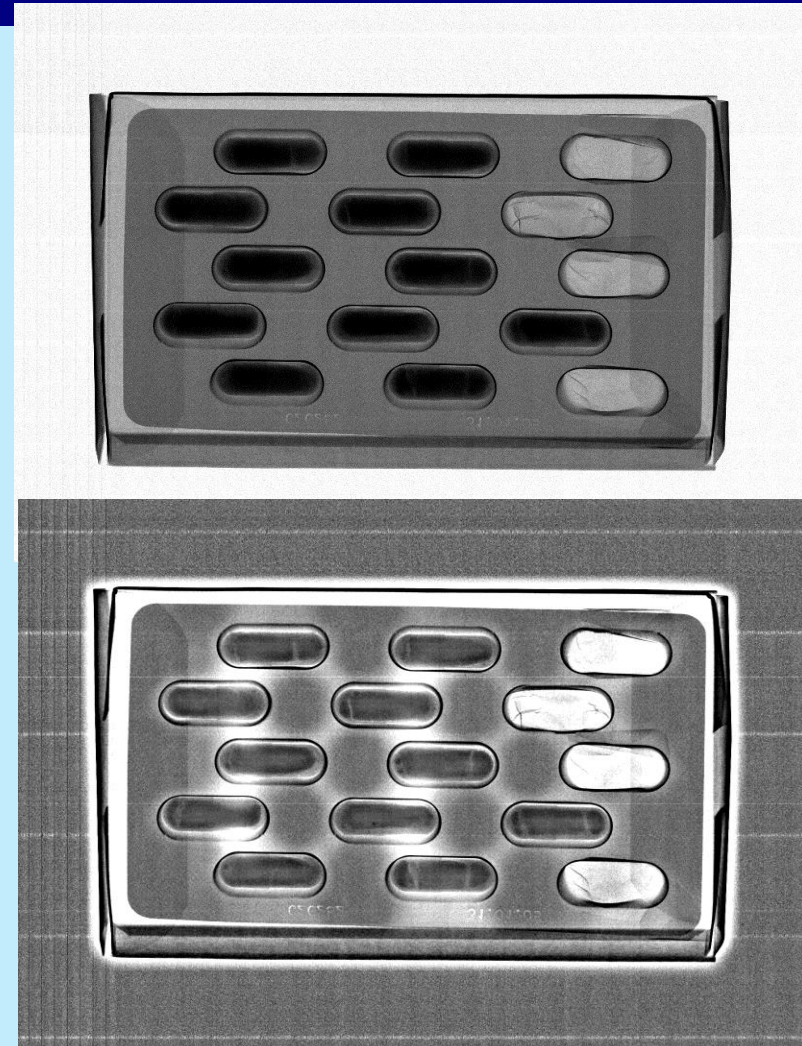

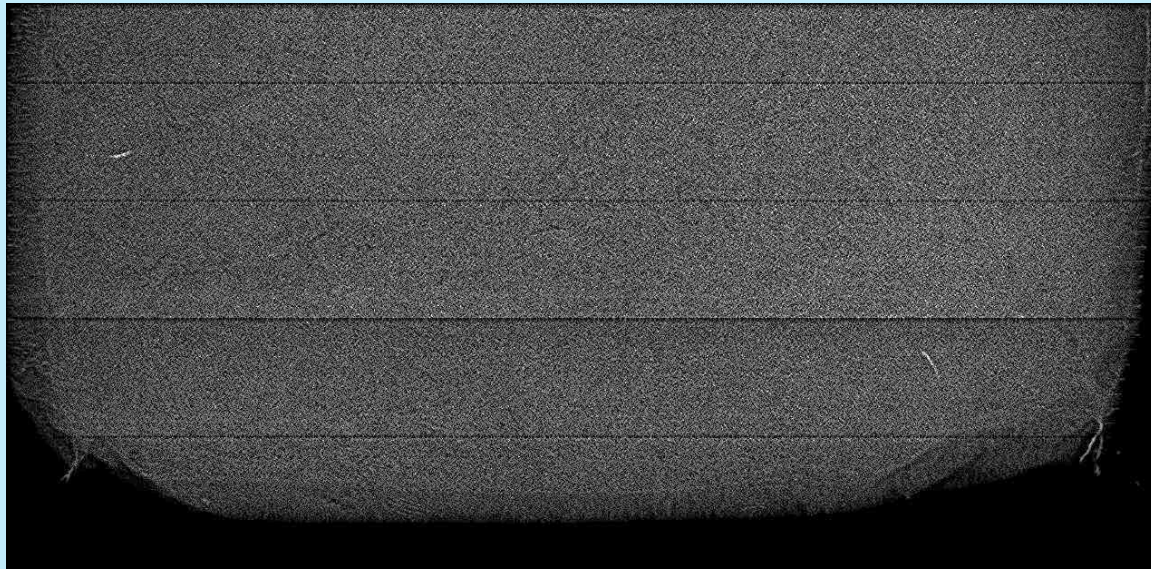
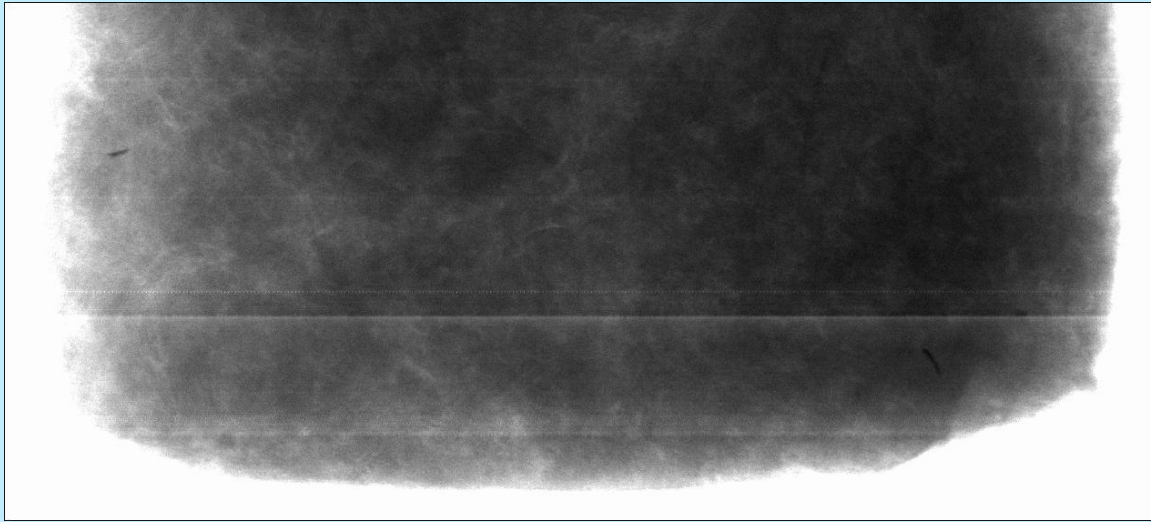

The quality of the image is the key for bone detection



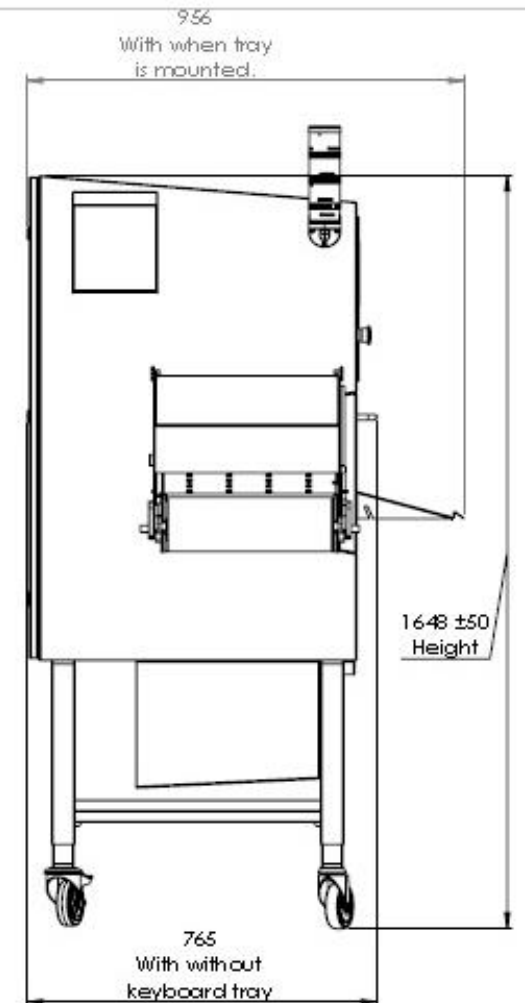
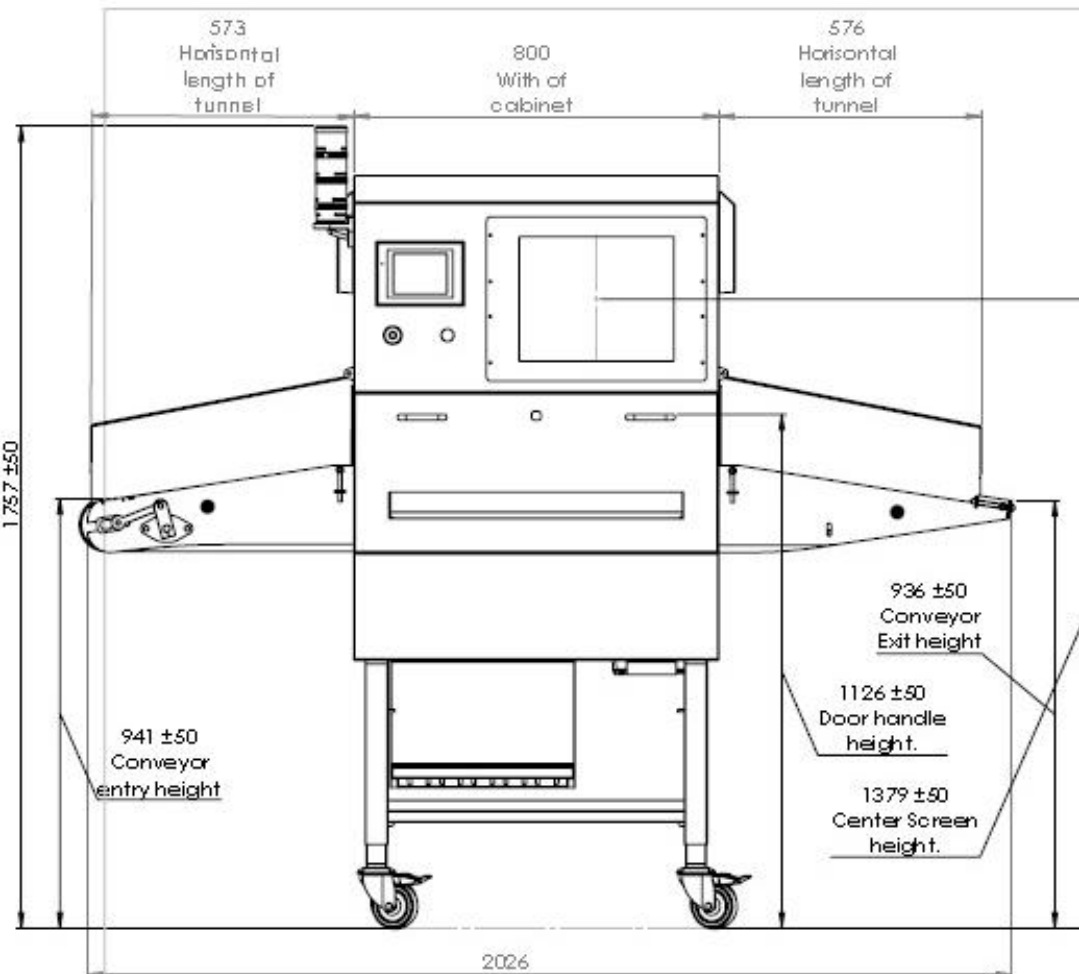

The machine have the possibility to be adjusted +/- 50 mm in height. For easy adaptation to the process line.

Comments:

LINE DRAWING OF THE
CONVEYOR SYSTEM WITH
CONVEYOR TUNNEL AND
SCREEN FOR THE MACHINE
WITH THE
CONVEYOR TUNNEL AND
SCREEN FOR THE MACHINE
WITH THE

DRAWN BY

Client

Project

Supplier

Date

10.04.2017

Drawn Date

Drawn By

Checked

Scale

Project number

Designer

InnospeXion
the invisible made visible

101_A_42_welded_conveyor

Scale

Scale

Scale

Low energy X-ray inspection

The HYMCIS from InnospeXion

(probably) **The worlds most sensitive, and highest resolution, X-ray systems for on-line control at manufacturing speeds up to 120 m/min**

Danish engineering – Made in Denmark

